

# Physics (and CMS) at the Crossroads



Jack Gunion  
U.C. Davis

USCMS, Granlibakken, July 7, 2014

# This is a good situation!

- We need experimental input to really understand where we are and to pursue the different directions.
- The greater the number of directions and uncertainties, the more the opportunities.
- CMS will play a major role for sure in many of these pursuits.
- New directions may emerge with new data.
- There are many interconnections between the directions:
  - Higgs as a portal to dark matter;
  - Collider limits on SUSY and naturalness vs. anthropics/string landscape;
  - Missing energy and dark matter;
  - Precision Higgs data and compositeness.
  - ....
  - ....

# 125 GeV Higgs and related

- $m_{h_{SM}} \sim 125.5$  GeV is both maximally interesting (many competing final states) and maximally confusing [SM (Stable or Metastable Vacuum) or BSM (Multi-Higgs, MSSM Higgs, Composite Higgs, ...)].

- SM?

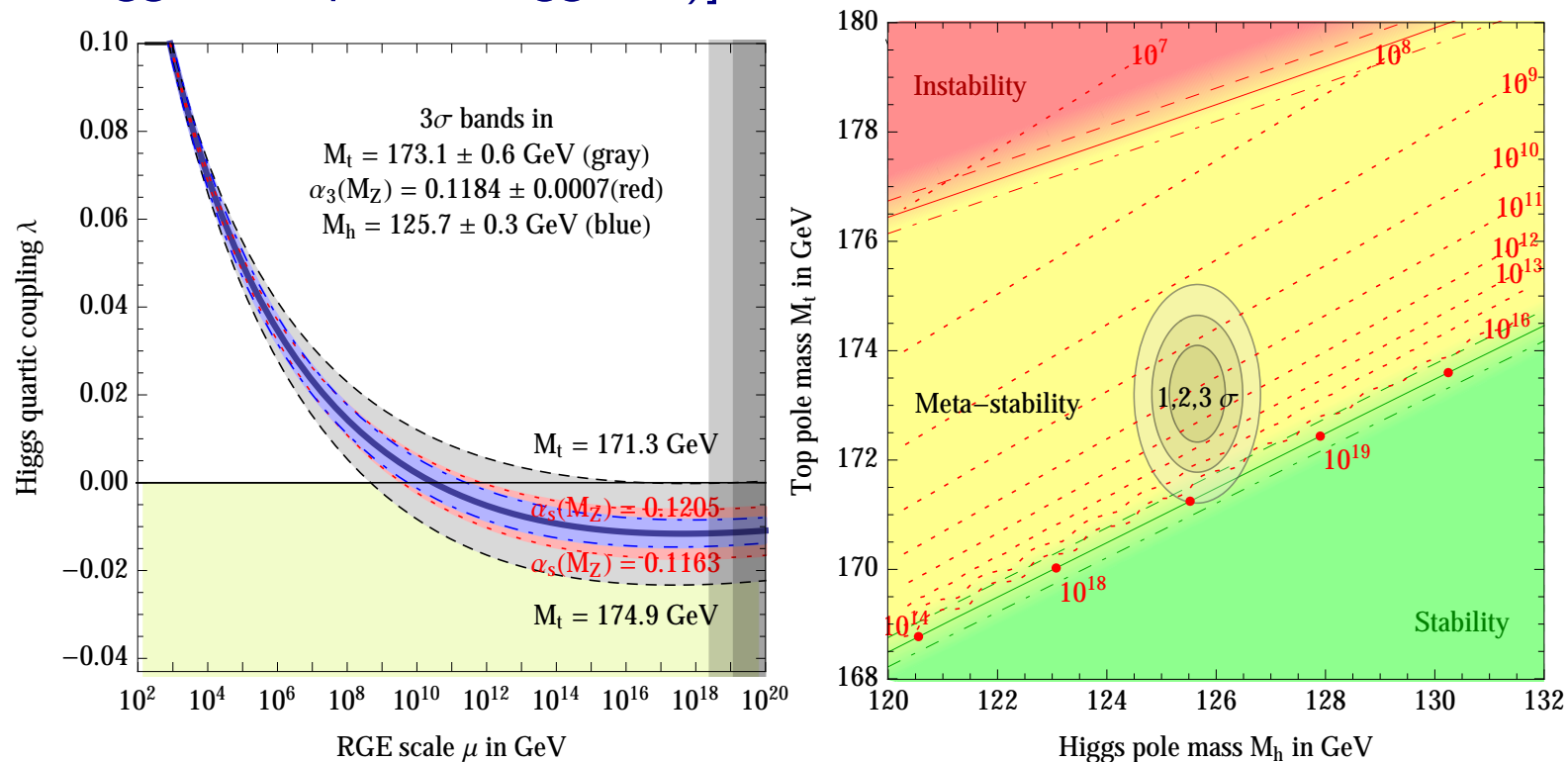

Figure 1: Pure SM implies  $\lambda(m_{Pl}) < 0$  for  $\mu > 10^{10} - 10^{12}$  GeV and metastable (but very long lifetime) early universe vacuum unless  $m_t$  is smaller than currently preferred. From arXiv:1307.3536, Buttazzo, *et al.*

- The coefficient  $m^2$  of the Higgs bilinear in the scalar potential is the order parameter that describes the transition between the symmetric phase ( $m^2 > 0$ ) and the broken phase ( $m^2 < 0$ ).

In principle,  $m^2$  could take any value between  $-m_{Pl}^2$  and  $+m_{Pl}^2$ , but quantum corrections push  $m^2$  away from zero towards one of the two end points of the allowed range.

- The hierarchy problem is that  $m^2 \sim 0$ , *i.e.* it sits near the boundary between the symmetric and broken phases.

Therefore, both the parameters of the Higgs potential, are near critical lines that separate the EW phase from a different (and inhospitable) phase of the SM.

Is criticality just a capricious numerical coincidence or is it telling us something deep?

The occurrence of criticality could be the consequence of symmetry.

- For instance, **exact** supersymmetry implies  $m^2 = 0$ . If supersymmetry is marginally broken,  $m^2$  would remain near zero, solving the hierarchy problem.
- But if no new physics at the LHC, what is the source of near-criticality?

The observation that both parameters in the Higgs potential are quasi-critical may be evidence for an underlying statistical system that approaches criticality.

*e.g.* **Multiverse**: our universe is not a special element of the multiverse where the

parameters have the peculiarity of allowing for life, but rather our universe is one of the most common products of the multiverse because it lies near an attractor critical point.

Rather than being selected by anthropic reasons, our universe is simply a very generic specimen within the most probable multiverse states.

- 125 GeV Higgs in SUSY?

What does a Higgs mass of 125-126 GeV tell us about natural theories?

- A Higgs mass smaller than 120 GeV would have been perfect for natural supersymmetry, while a mass larger than 130 GeV would have excluded the simplest scenarios.
- If the Higgs mass is really 125 GeV, right in the middle, theorists are perplexed/unsure of what to think.

It is often said that in the MSSM, a Higgs mass of 125 GeV can be reached, but only for extreme values of the parameters, especially those of the stop.

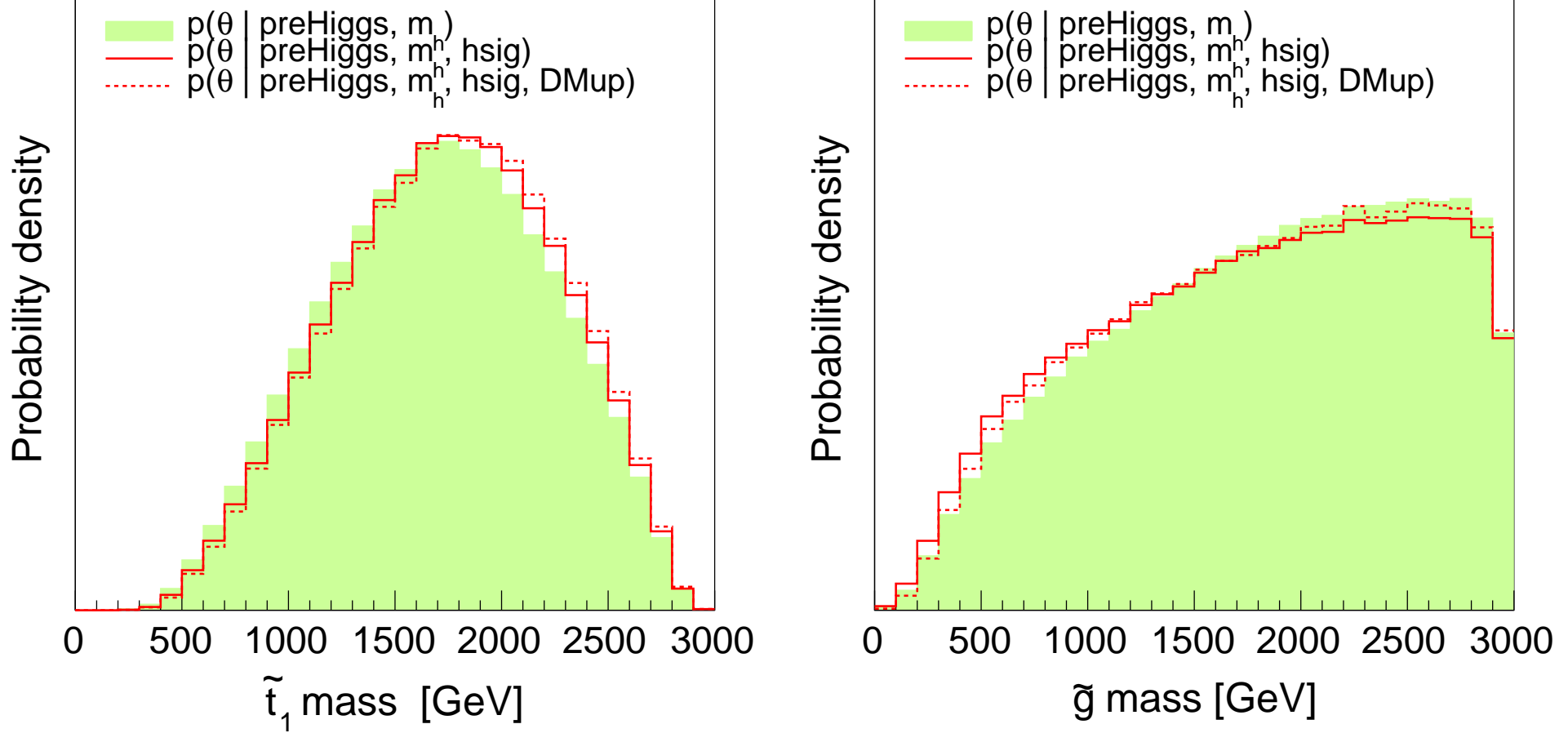

Figure 2: pMSSM bayesian probability distributions (arXiv:1312.7027, Dumont *et al.*). Left:  $m_{\tilde{t}_1}$ ; Right:  $m_{\tilde{g}}$ .

Fig. 2 shows significant probability for  $m_{\tilde{t}_1}, m_{\tilde{g}} < 1$  TeV even after precision Higgs data. CMS is working to exclude these scenarios, but has a ways to go.

- What can be said is that certain natural setups, where parameters are correlated, are in bad shape (for instance gauge mediation, constrained MSSM), but the idea of low-energy supersymmetry of a pMSSM variety (which generically means

- no high-scale extrapolation, let alone unification) is not (yet) dead.
- Of course, the NMSSM still provides a good escape from being particularly unnatural **even when GUT b.c. are employed**. For example, in the NUH-NMSSM (NUH=non-universal Higgs soft masses squared), one has

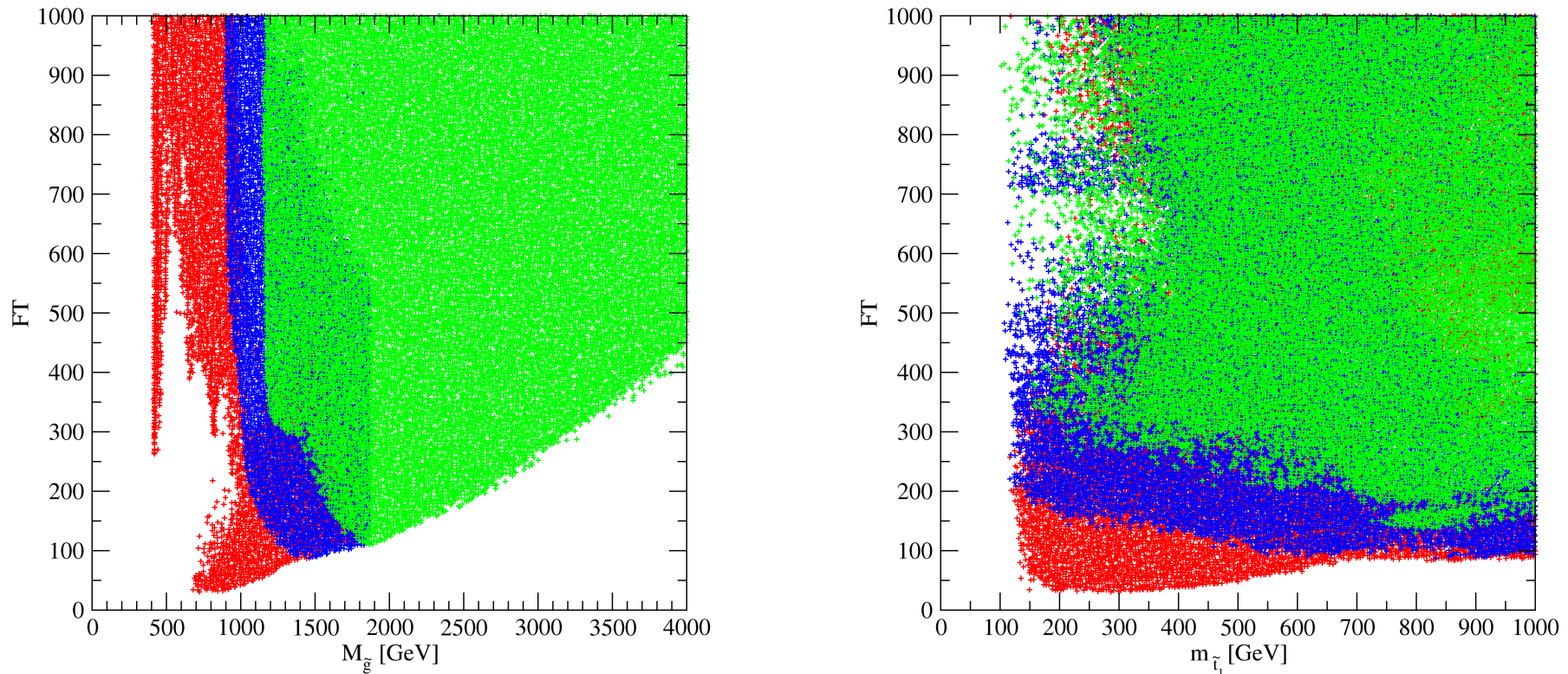

Figure 3: Fine Tuning in the NMSSM vs.  $m_{\tilde{g}}$  and  $m_{\tilde{\tau}_1}$ , arXiv:1405.6647, Ellwanger and Hugonie. Red: absolutely excluded by LHC searches; Blue: still allowed if LSP=highly singlino; Green: still allowed even if LSP not singlino.

We see:

- \* The LHC forbidden red region increases the lower bound on  $FT$  from  $\sim 20$  to  $FT \gtrsim 80$ ; the NMSSM-specific alleviation (blue region) has a minor impact on  $FT$ .
  - \* The dominant contribution to  $FT$  originates from  $M_{1/2}$  (i.e. the gluino mass at the GUT scale), or from the soft Higgs mass term  $m_{H_u}^2$ .
  - \* If one requires unification of  $m_{H_u}$  and  $m_{H_d}$  with  $m_0$ ,  $FT$  increases to  $\gtrsim 400$ .
  - \* In the MSSM – after imposing LHC constraints on squark and gluino masses, defining  $FT$  with respect to parameters at the GUT scale and allowing for non-universal Higgs mass terms at the GUT scale – one finds  $FT \gtrsim 1000$ .
  - \* The impact of  $M_{1/2}$  on  $FT$  is actually indirect: heavy gluinos lead to large radiative corrections to the stop masses which, in turn, lead to large radiative corrections to the soft Higgs mass terms.  
Therefore, if one defines  $FT$  with respect to parameters at a lower scale, low  $FT$  is typically related to light stops (r.h. plot).
- If the LHC eventually definitively forces all SUSY partners to be heavy and we simply give up on naturalness in a quantitative sense (but not in the sense that we give up on the symmetry), then  $m_h \sim 126$  GeV becomes quite accidental and forces another kind of fine tuning of the cutoff scale.  
For example, Fig. 4 (l.h. plot) shows that a Higgs mass of 125 GeV rules out the idea of Split Supersymmetry with a high scale, say larger than  $10^8$  GeV.



However, it fits very well with Split Supersymmetry with a low scale.

The r.h. plot shows that the correct  $m_h$  requires a conspiracy between the SUSY breaking scale,  $M_{SS}$ , and  $\tan\beta$ .

Predicted range for the Higgs mass

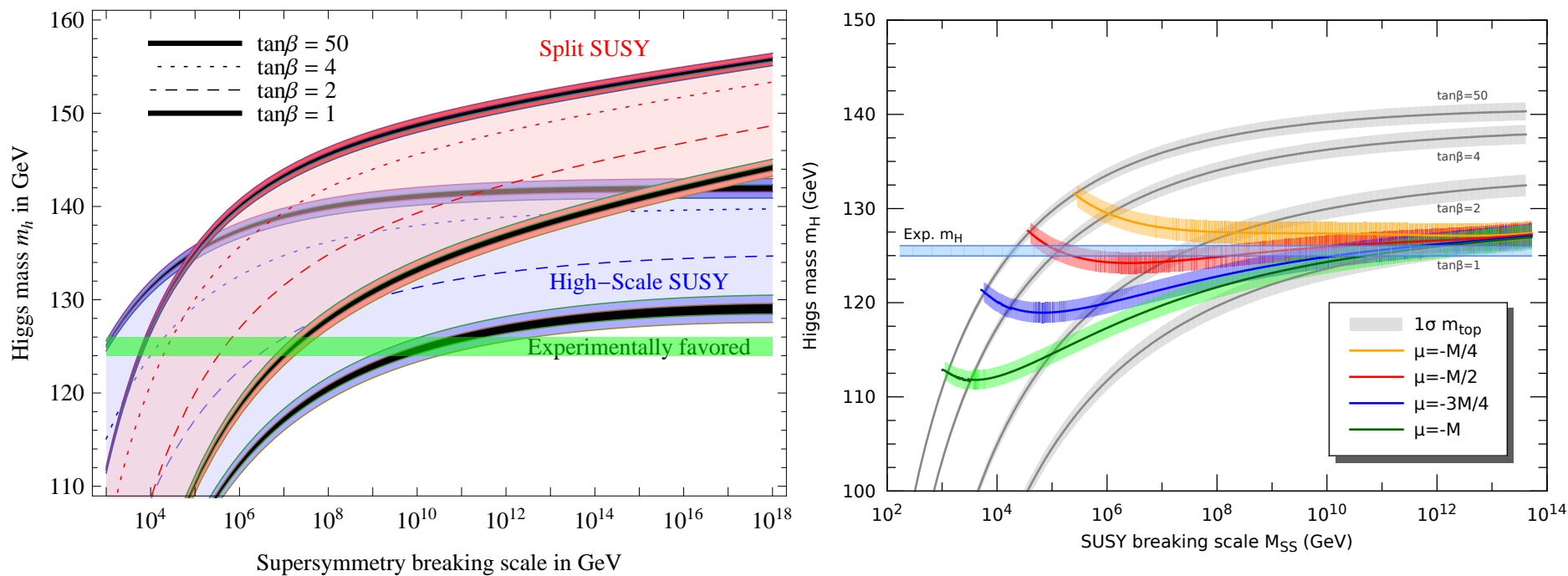

Figure 4: Left: NNLO prediction for the Higgs mass  $M_h$  in High-Scale Supersymmetry (blue, lower) and Split Supersymmetry (red, upper) for  $\tan\beta = \{1, 2, 4, 50\}$  from arXiv:1108.6077, Giudice *et al.*. Right: Higgs mass versus SUSY breaking scale  $M_{SS}$ . The grey bands correspond to the Higgs mass for different values of  $\tan\beta$ , for  $X_t = 0$ , without imposing unification of Higgs soft parameters. The other colored bands correspond to imposing  $\tan\beta$  values consistent with unification of soft terms,  $m_{H_u} = m_{H_d}$ . From arXiv:1301.5167, Ibanez, *et al.*

## Other Higgs Bosons

- Even if the 126 GeV Higgs boson turns out to be extremely SM-like, that does not mean that there are no other Higgs bosons nor does it mean that in models with extra Higgs bosons those Higgs bosons must be very heavy (the decoupling limit).
- For example, in the 2HDM there is the so-called “Alignment Limit” in which parameters are chosen so that  $\sin(\beta - \alpha) = 1$ , *i.e.*  $\alpha = \beta - \pi/2$ , in which case all  $h$  couplings are exactly equivalent to those of the SM.

	Type I and II	Type I		Type II	
Higgs	$C_V$	$C_U$	$C_D$	$C_U$	$C_D$
$h$	$\sin(\beta - \alpha)$	$\cos \alpha / \sin \beta$	$\cos \alpha / \sin \beta$	$\cos \alpha / \sin \beta$	$-\sin \alpha / \cos \beta$
$H$	$\cos(\beta - \alpha)$	$\sin \alpha / \sin \beta$	$\sin \alpha / \sin \beta$	$\sin \alpha / \sin \beta$	$\cos \alpha / \cos \beta$
$A$	0	$\cot \beta$	$-\cot \beta$	$\cot \beta$	$\tan \beta$

Table 1: Tree-level vector boson couplings  $C_V$  ( $V = W, Z$ ) and fermionic couplings  $C_F$  ( $F = U, D$ ) normalized to their SM values for the Type I and Type II 2HDMs.

Of course, at the moment there is still a fair amount of freedom.

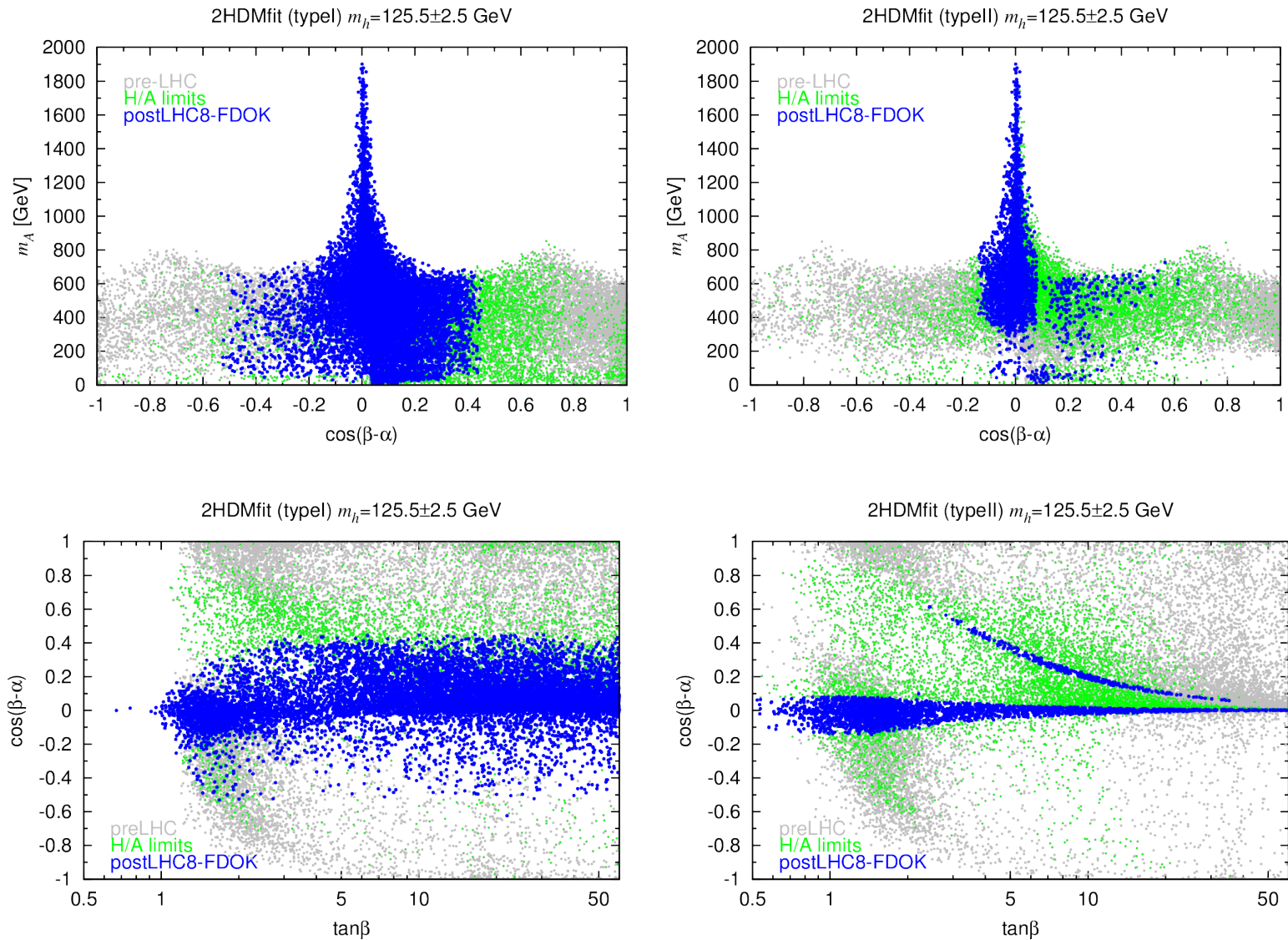

Figure 5: Grey points satisfy preLHC constraints, while green points satisfy in addition the LHC limits on  $H$  and  $A$  production. Blue points satisfy precision Higgs fitting in addition. Extra type II branch = wrong-sign- $C_D^h$ .

- Prospects for LHC observation of the  $H$ ,  $A$ ,  $H^\pm$  are significant. *e.g.*  $\tau\tau$  final state.

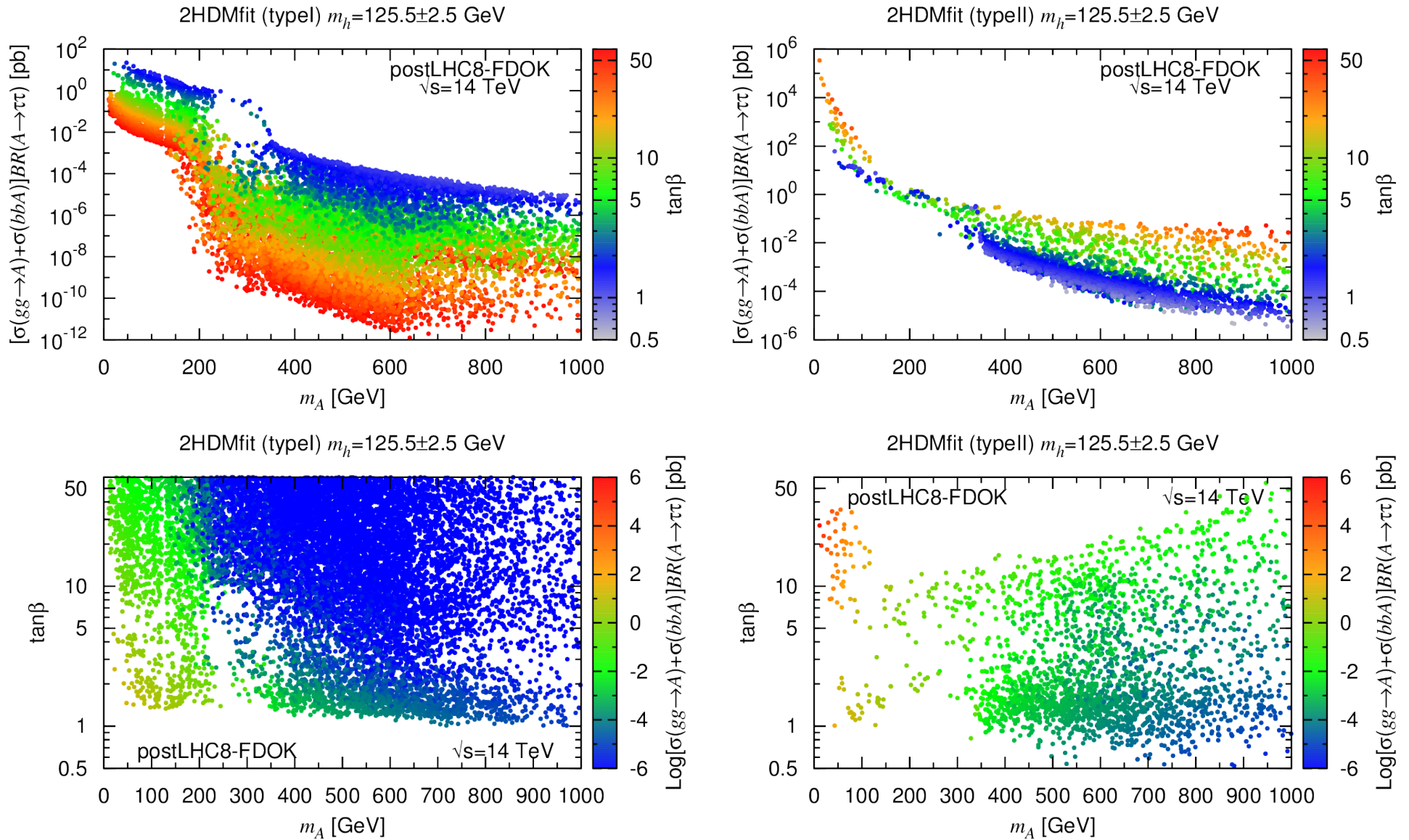

Figure 6: 2HDM points agreeing at 95% C.L. with precision Higgs data as well as  $B$  physics, ....

Note especially the very large possible cross sections (esp. Type II) of points at low  $m_A$  (with  $\mathcal{B}(h \rightarrow AA) \lesssim 0.1$  to avoid messing with  $h$  fits). Remarkably, they are still allowed by LEP and by existing 7+8 TeV analyses, although I feel certain that the existing analyses can be extended to  $M_{\tau\tau} < 90$  GeV, in which case the bulk of these points would be eliminated (or observed).

These low- $m_A$  points are also not exactly SM-like in that  $C_\gamma^h \lesssim 0.95$  because of a non-decoupling heavy charged Higgs while  $C_g^h \sim 1.13$  because the  $hb\bar{b}$  Yukawa coupling is opposite in sign (but same magnitude) from the SM value.

– According to the recent Snowmass studies, the LHC can measure  $C_g^h$  to 6–8% for  $L = 300 \text{ fb}^{-1}$  and 3–5% for  $L = 3000 \text{ fb}^{-1}$ , based on fitting all the rates rather than directly observing the  $gg$  final state.

At the ILC,  $e^+e^- \rightarrow Z^* \rightarrow Zh$  determines the  $ZZh$  coupling very accurately and isolation of the  $gg$  final state is easier. The error on  $C_g^h$  estimated is 2% for a combination of  $L = 250 \text{ fb}^{-1}$  at  $\sqrt{s} = 250$  GeV and  $L = 500 \text{ fb}^{-1}$  at  $\sqrt{s} = 500$  GeV.

Thus, both the LHC and ILC will be able to determine whether or not  $C_D^h$  is positive using the indirect fit and direct measurement of  $C_g^h$ , respectively.

– The 5% suppression of  $C_\gamma^h$  for  $C_D^h < 0$  should be measurable at the  $\sqrt{s} = 14$  TeV LHC run for  $L = 3000 \text{ fb}^{-1}$ .

Of course, there is also the  $\mu\mu$  final state. There are a number of relevant CMS analyses (probably also ATLAS). Recall the CMS analysis of arXiv:1206.6326, which obtained limits of  $\sigma(gg \rightarrow A)\mathcal{B}(A \rightarrow \mu\mu) \leq 2 - 3$  pb for  $m_A \in [11 - 14]$  GeV using  $1.3 \text{ fb}^{-1}$  of data. This can be compared to the predictions shown in Fig. 7.

From this, it seems that Type-II is ruled out for  $m_A < 14$  GeV, but not Type-I.

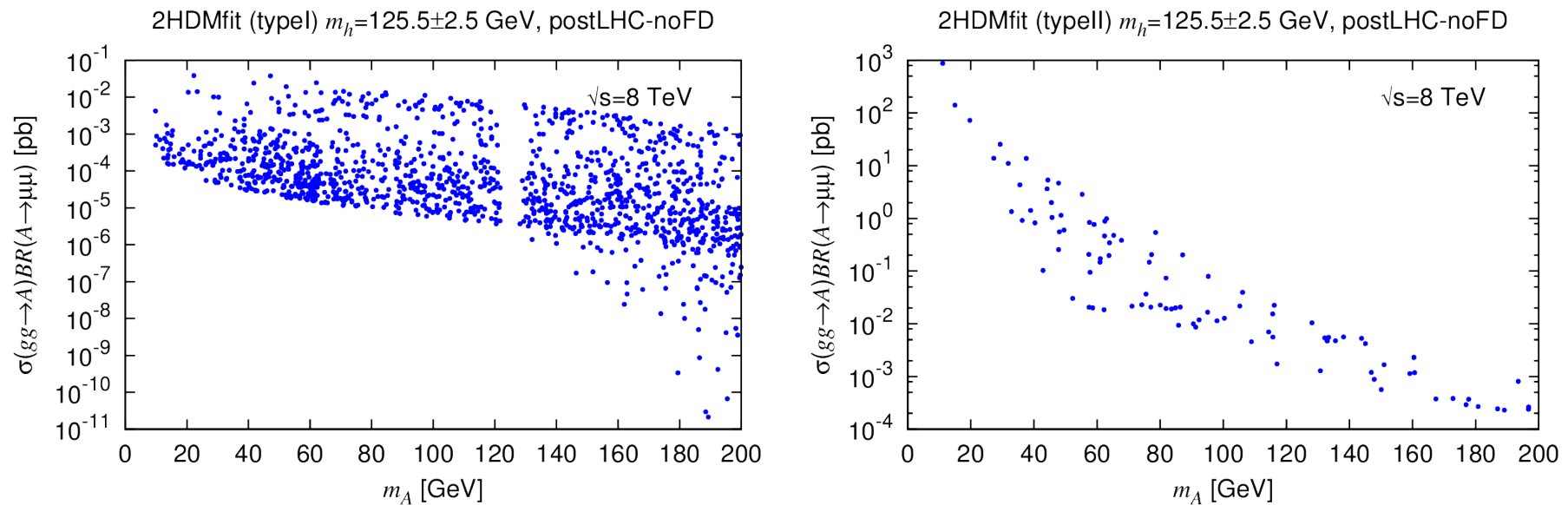

Figure 7: We plot  $\sigma(gg \rightarrow A)\mathcal{B}(A \rightarrow \mu\mu)$  for  $m_A < 200$  GeV in models of Type-I and Type-II. All points pass all constraints at the postLHC8 level, including  $m_h = 125$  GeV higgs fitting.

An aside: there are limits from CMS PAS HIG-13-007 of order  $0.02 - 0.03$  pb for  $m_A \in [100, 150]$  GeV assuming that the  $A$  and  $H$  behave similarly in the  $\mu\mu$  channels as regards efficiencies and acceptance. = getting close.

$A$  production with exotic decays such as  $A \rightarrow Zh$  can have large cross section. In fact, current data are already relevant in limiting these scenarios.

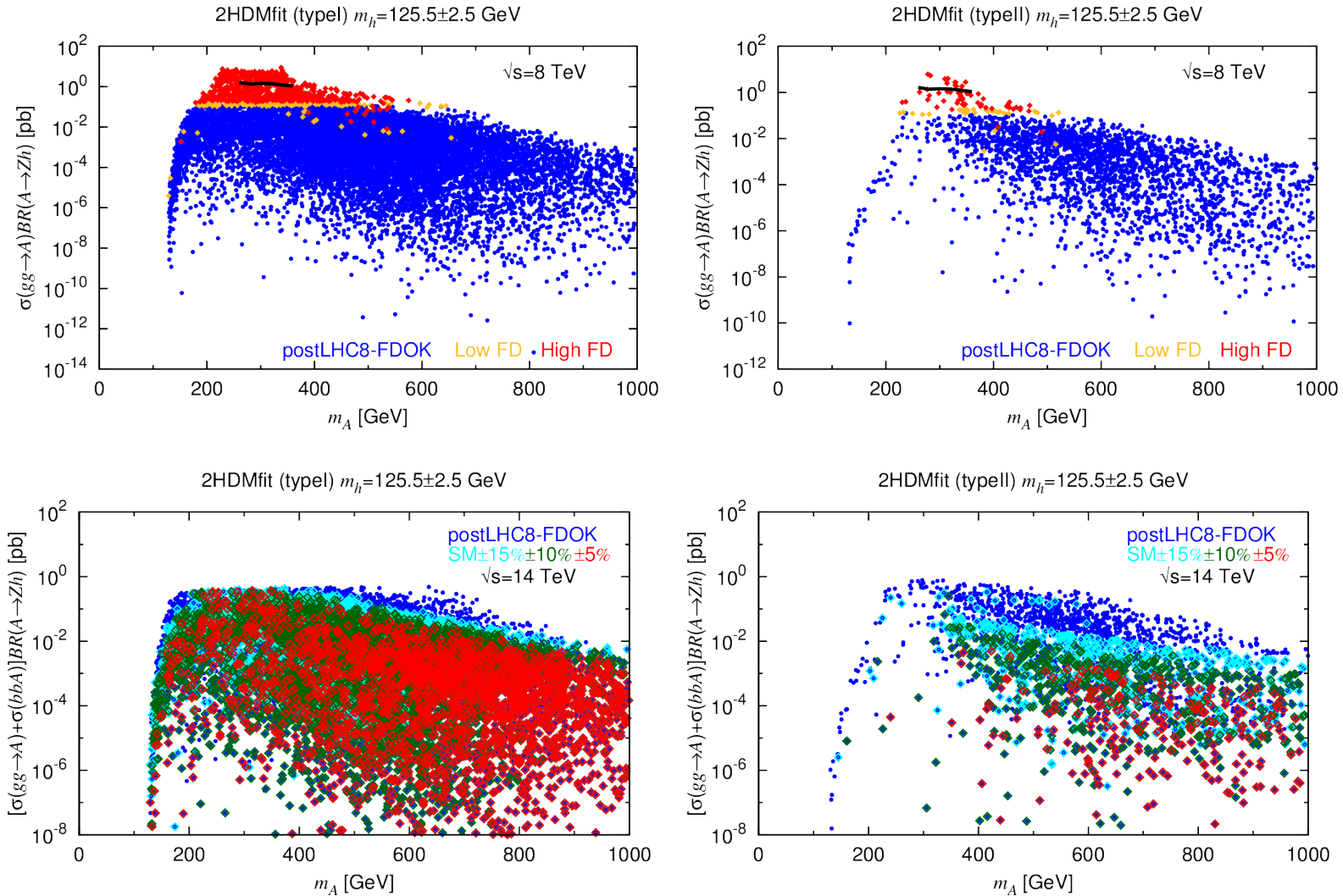

Figure 8:  $gg$  and  $bb$  production of  $A$  with  $A \rightarrow Zh$ . Top:  $\sqrt{s} = 8$  TeV. Bottom:  $\sqrt{s} = 14$  TeV. Effect of increasingly SM-like  $h$  is shown. Black line: early CMS limits; would have screwed up  $h$  fits.

- In the MSSM,  $m_A$  is tied to  $m_h$  and cannot be small. Expectations are generically that the  $A$ ,  $H$  and  $H^\pm$  will be heavy. In the pMSSM, we have the following.

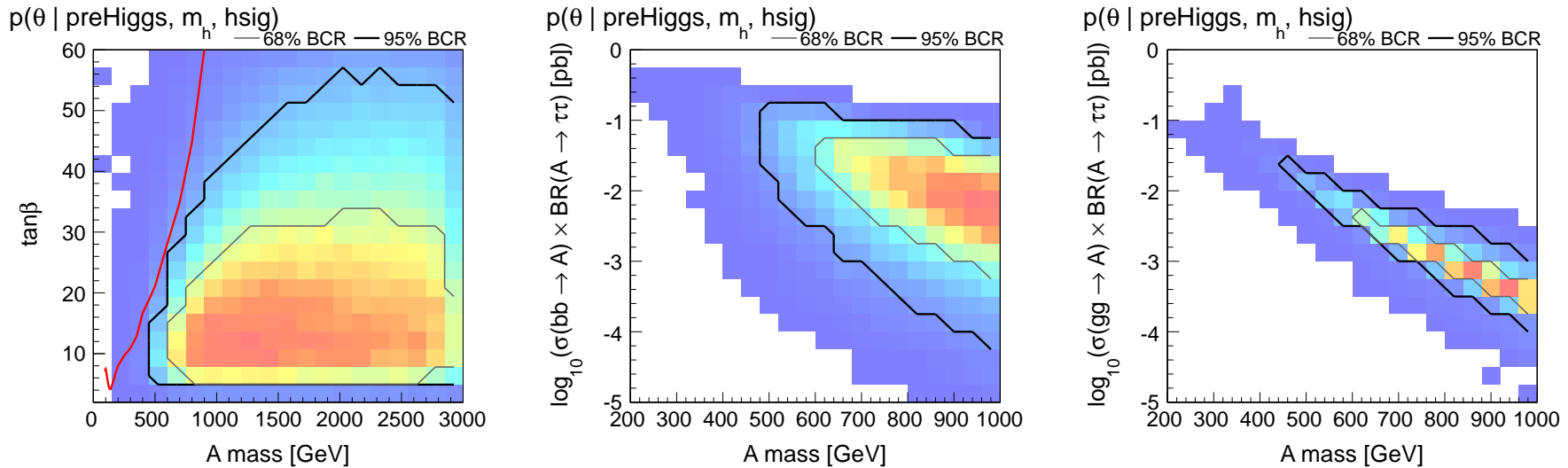

Figure 9: pMSSM results for the  $A$  after Higgs fitting. SUSY limits as per SUS-13-020 have no impact. Cross sections are for  $\sqrt{s} = 14$  TeV. Much of the predicted range can be probed at the next LHC run!

- In the NMSSM, we have  $h_1, h_2, h_3$  and  $a_1, a_2$  and  $H^\pm$ . Many possibilities!

It is still very relevant to consider CP-even Higgs production with decay to  $a_1 a_1$ . Some recent scans from Barducci are of interest. He considers  $A_\kappa \rightarrow 0$ ,  $m_{a_1} < 10$  GeV, and demands that  $h_1$  or  $h_2$  fit the Higgs data at 95% C.L. He also computes the contribution of the non-SM-like  $h_2$  or  $h_1$  to the  $4\tau$  final state. NB.  $4\tau$  mass resolution is poor.



# $h_{1,2}^{SM} \rightarrow a_1 a_1 \rightarrow 4\tau$ topology ( $m_{a_1} < 10$ GeV) LHC8

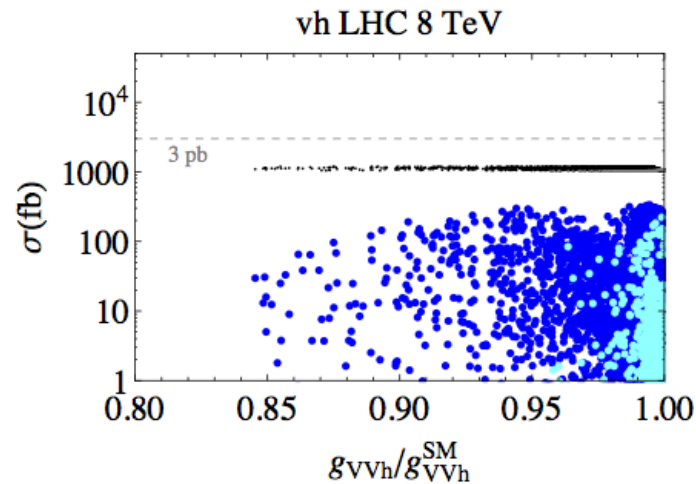
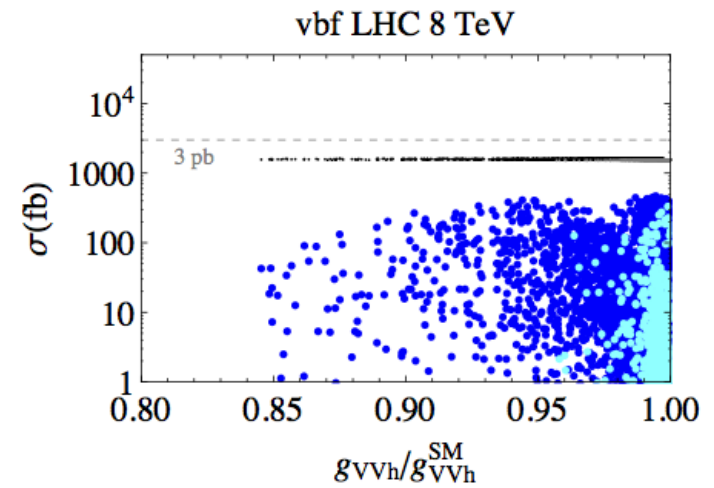
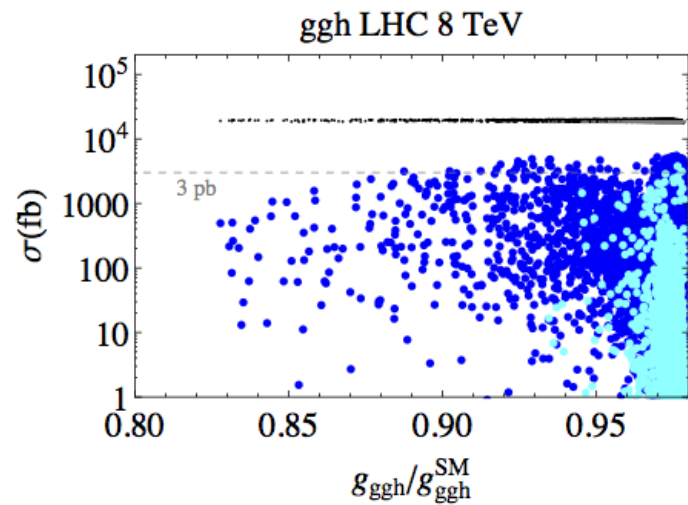

- Blue/Cyan:  
 $h_1/h_2$  SM Higgs boson
- Black/Gray:  
 $\sigma(pp \rightarrow h^{SM} X)$

# $h_{1,2}^{SM} \rightarrow a_1 a_1 \rightarrow 4\tau$ topology ( $m_{a_1} < 10$ GeV) LHC8

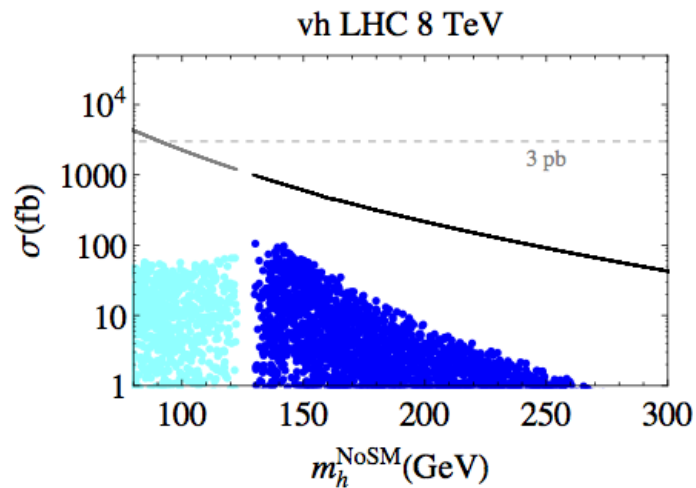
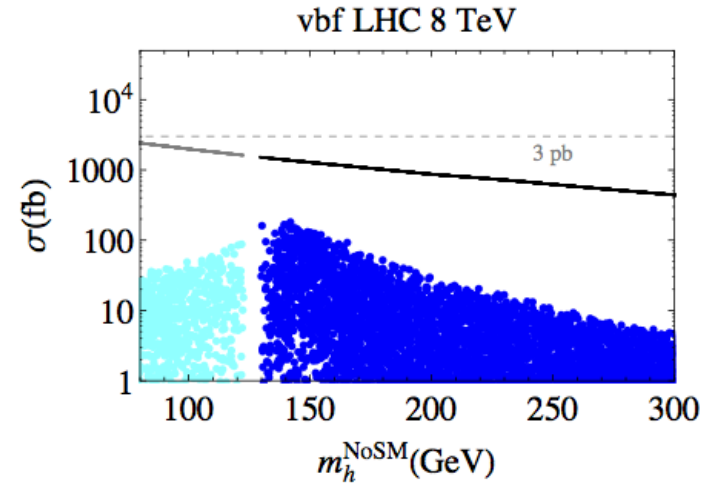
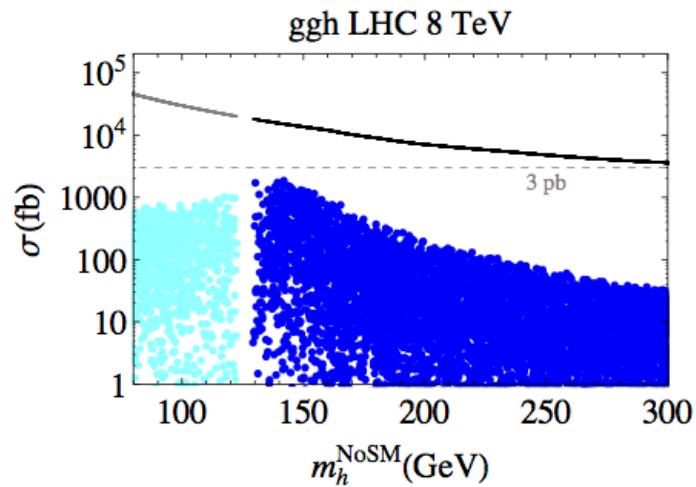

- Blue/Cyan:  
 $h_1/h_2$  SM Higgs boson
- Black/Gray:  
 $\sigma(pp \rightarrow h^{\text{noSM}} X)$

Contribution of both the lightest CP even Higgs to the signal

# SUSY

- We should never give up on SUSY or some other high scale theory to regulate Higgs mass. Symmetry/... has always worked in the past and most theorists believe it applies now, even if it is at an unnaturally high scale.
- But, we have not reached that point yet! Aside from the NMSSM scans mentioned earlier which had modest FT, but did not include  $\delta a_\mu$ , there were also the earlier NUH-NMSSM scans of arXiv:1201.0982, Gunion *et al.*

We found 'perfect' points that satisfied everything, including  $\delta a_\mu$ , and that were at the time uncomfortably SM-like for the 125 GeV state. Model II had  $A_\lambda = A_\kappa = 0$  at  $M_U$  while Model III allowed any values. Sample points are below — Starred points are the perfect points satisfying all constraints, including  $\delta a_\mu > 5.77 \times 10^{-10}$  and  $0.094 < \Omega h^2 < 0.136$ . Unstarred points are the almost perfect points that have  $4.27 \times 10^{-10} < \delta a_\mu < 5.77 \times 10^{-10}$  and  $0.094 < \Omega h^2 < 0.136$ .

The only thing wrong with these points is that at  $\sigma_{SI} \sim \text{few} \times 10^{-8}$  pb, they are a bit above the new LUX limit.

Pt. #	Model II			Model III			
	1*	2*	3	4*	5	6	7
$\tan \beta(m_Z)$	17.9	17.8	21.4	15.1	26.2	17.9	24.2
$\lambda$	0.078	0.0096	0.023	0.084	0.028	0.027	0.064
$\kappa$	0.079	0.011	0.037	0.158	-0.045	0.020	0.343
$m_{1/2}$	923	1026	1087	842	738	1104	1143
$m_0$	447	297	809	244	1038	252	582
$A_0$	-1948	-2236	-2399	-1755	-2447	-2403	-2306
$A_\lambda$	0	0	0	-251	-385	-86.8	-2910
$A_\kappa$	0	0	0	-920	883	-199	-5292
$m_{h_1}$	124.0	125.1	125.4	123.8	124.5	125.2	125.1
$m_{h_2}$	797	1011	1514	1089	430	663	302
$m_{a_1}$	66.5	9.83	3.07	1317	430	352	302
$C_u$	0.999	0.999	0.999	0.999	0.999	0.999	0.999
$C_d$	1.002	1.002	1.001	1.003	1.139	1.002	1.002
$C_V$	0.999	0.999	0.999	0.999	0.999	0.999	0.999
$C_{\gamma\gamma}$	1.003	1.004	1.004	1.004	1.012	1.003	1.001
$C_{gg}$	0.987	0.982	0.988	0.984	0.950	0.986	0.994
$\mu_{\text{eff}}$	400	447	472	368	421	472	477
$m_{\tilde{g}}$	2048	2253	2397	1876	1699	2410	2497
$m_{\tilde{q}}$	1867	2020	2252	1685	1797	2151	2280
$m_{\tilde{b}_1}$	1462	1563	1715	1335	1217	1664	1754
$m_{\tilde{t}_1}$	727	691	775	658	498	784	1018
$m_{\tilde{e}_L}$	648	581	878	520	1716	653	856
$m_{\tilde{e}_R}$	771	785	1244	581	997	727	905
$m_{\tilde{\tau}_1}$	535	416	642	433	784	443	458
$m_{\tilde{\chi}_1^+}$	398	446	472	364	408	471	478
$m_{\tilde{\chi}_1^0}$	363	410	438	328	307	440	452

Since  $m_{\tilde{t}_1}$  and  $\mu_{\text{eff}}$  are both modest in size, these scenarios have modest FT.

- Of course, it is very possible that demanding substantial unification at  $M_U$  is simply not nature's choice given the plethora of string landscapes that would have 'random'  $\sim$  TeV SUSY parameters along with other new physics at intermediate scales.
- Thus, we should consider the pMSSM where all inputs are at the  $\sim$  TeV scale and extrapolation to higher scales of order  $M_U$  or  $m_{Pl}$  typically fails without additional new physics entering.
- The same plots given earlier suggest in the pMSSM context that quite large masses for superparticles have the highest probability given the Higgs data.
- Current LHC analyses within the pMSSM context (CMS) do not dramatically alter the  $m_{\tilde{t}_1}$  distribution (which was already pushed to large values by  $b \rightarrow s\gamma$  limits), but do push  $m_{\tilde{g}}$  and  $m_{\tilde{\chi}_1^0}$  values higher.

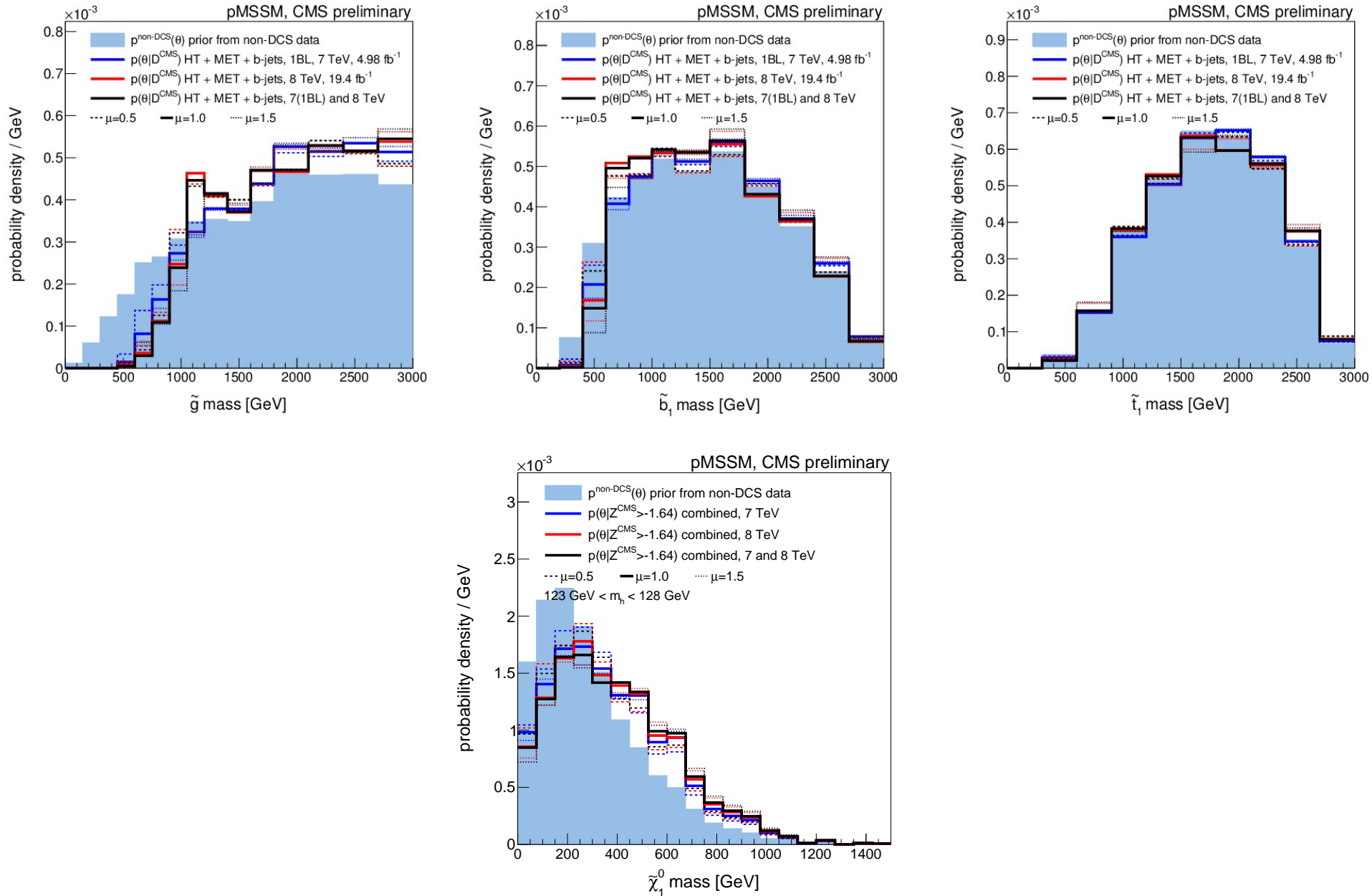

Figure 10: Marginalized pMSSM distributions from PAS-13-020, Vanelderren, Sekmen *et al.*

- But, these analyses are only valid for  $c\tau < 10$  mm. One should ask how probable this chargino lifetime is. After a simple Higgs mass cut and requiring  $\Omega h^2$  within the WMAP/Planck type window, large  $c\tau$  is emphasized. But, as has long been known, correct  $\Omega h^2$  is highly improbable in the overall pMSSM parameter space.

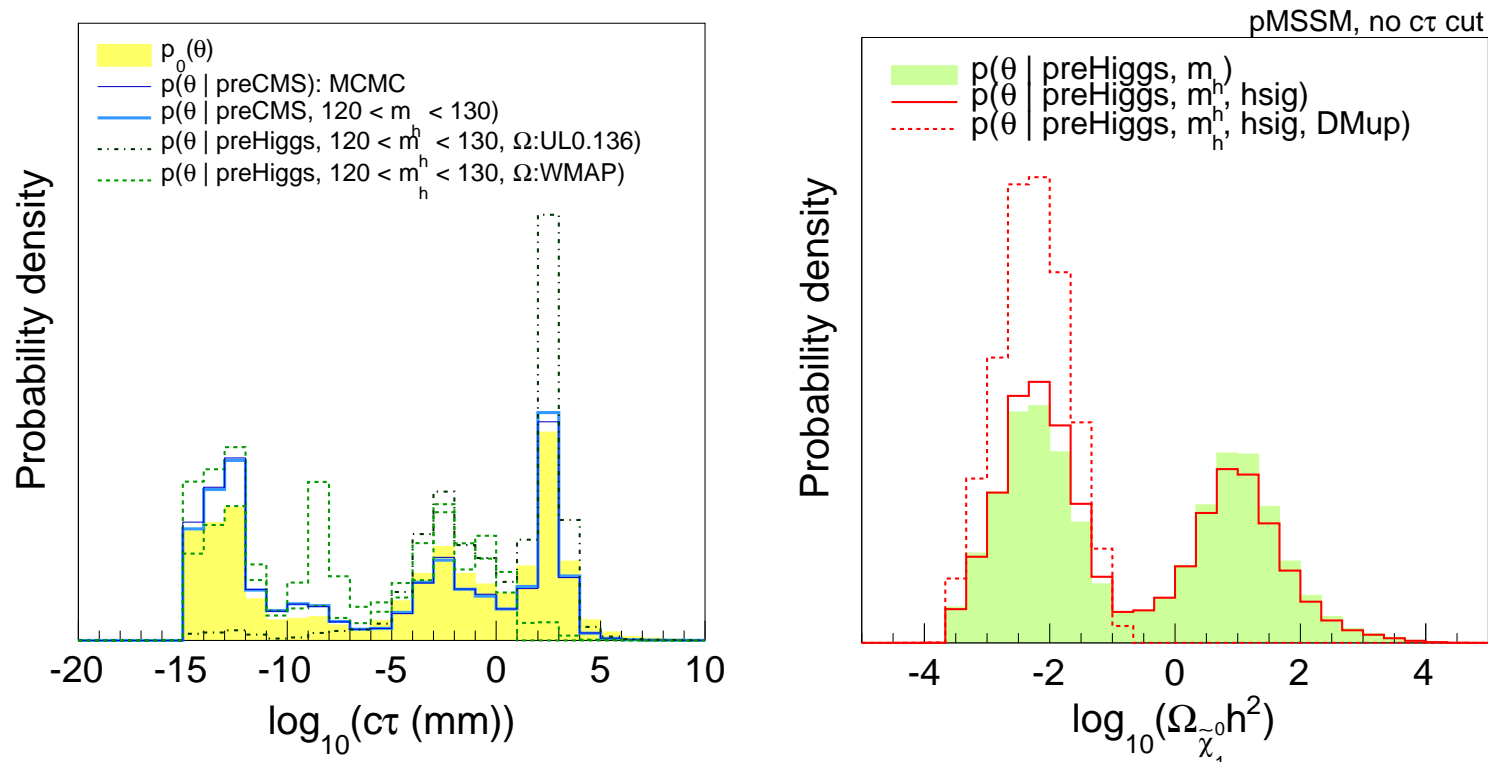

Figure 11: Marginalized pMSSM  $c\tau(\tilde{\chi}_1^\pm)$  and  $\Omega h^2$  distributions (arXiv:1312.7027, Dumont *et al.*).

- An EXO analysis has targeted large  $c\tau$  as below. **Note:** the most probable  $c\tau$  values from an overall pMSSM scan are precisely those not probed by either the PAS-EXO-13-006 or PAS-SUS-12-030 analyses.

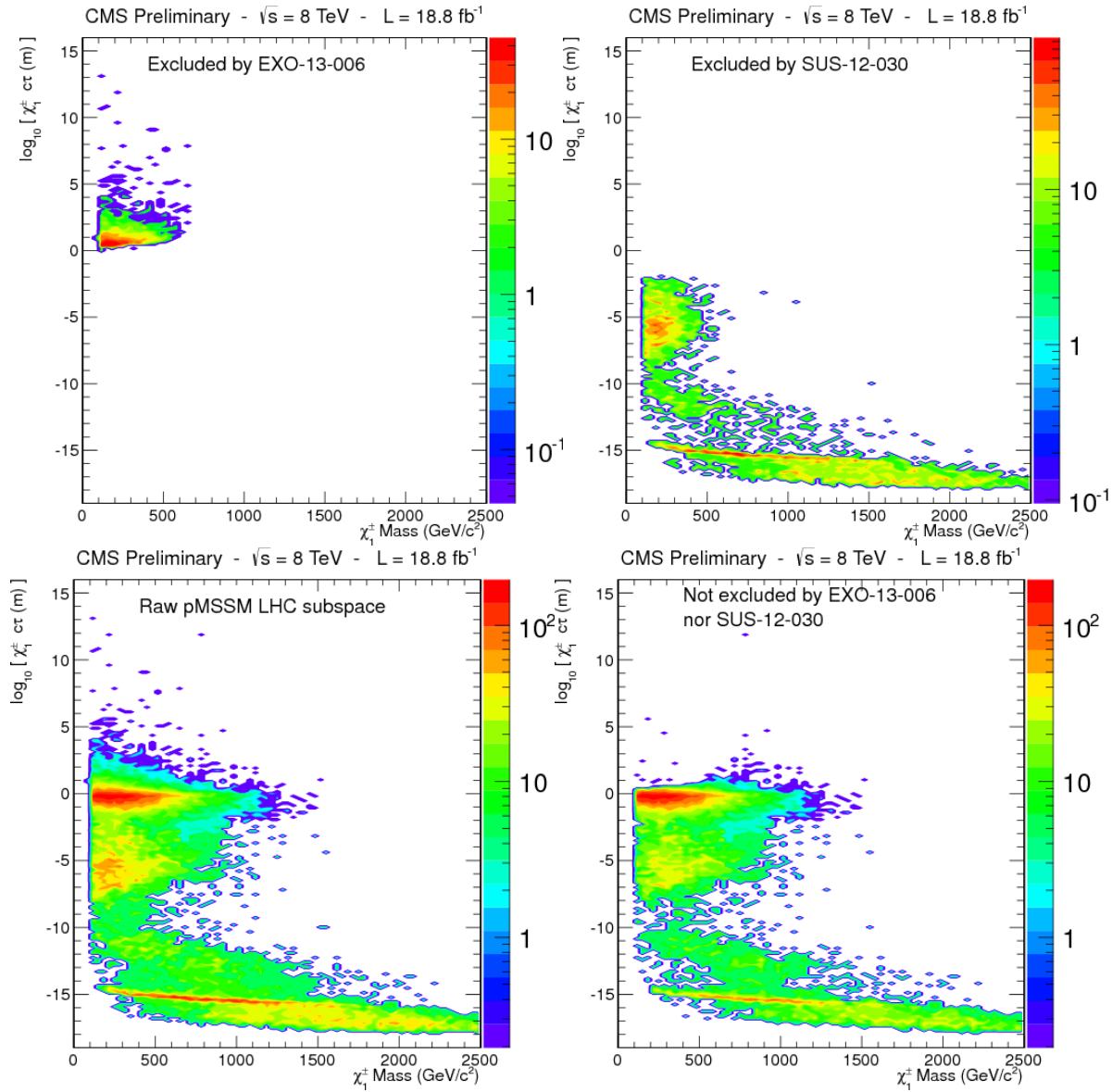

Figure 12: Marginalized pMSSM  $CT$  exclusion/nonexclusion distributions from PAS-EXO-13-006 and PAS-SUS-12-030.



- After  $CT$  cut, the expectations for DM are as shown below.  $\Rightarrow$  little 7+8 TeV data impact.

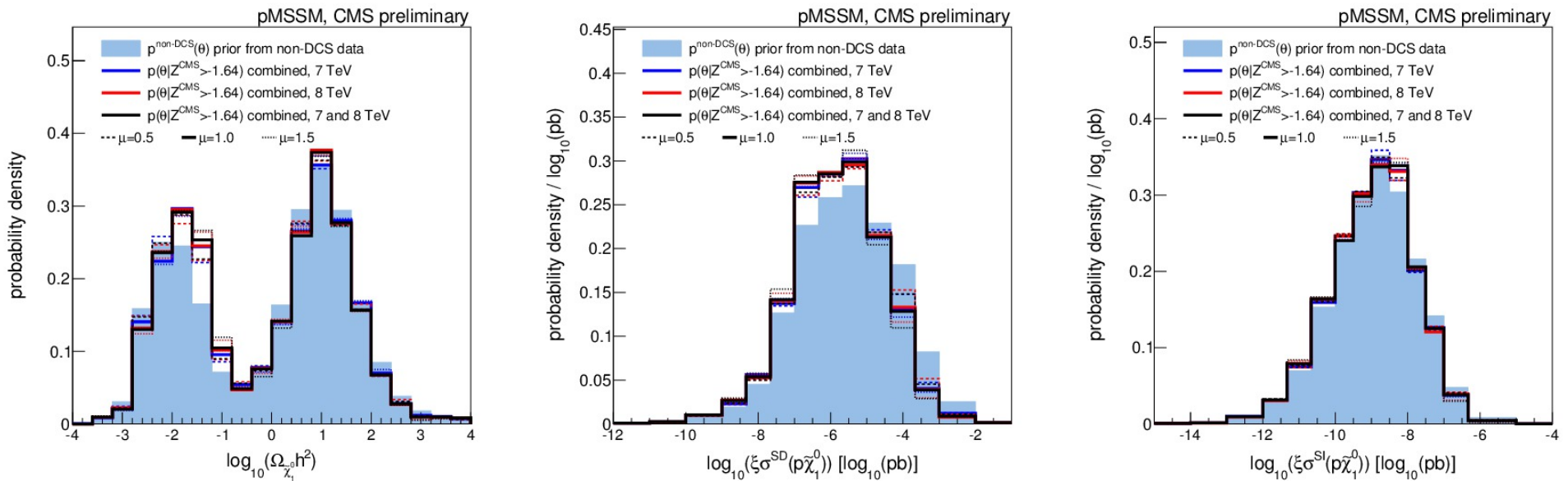

Figure 13: Marginalized pMSSM distributions from PAS-13-020, Vanelderren, Sekmen *et al.*

- **RPV Models**

Perhaps we should take these more seriously since they can have smaller Fine Tuning in cases where the mass limits, especially on stops and gluinos are weaker than for RP conserving models.

Especially difficult are the baryonic RPV scenarios since signals have little missing energy and large hadronic backgrounds.

Some examples of recent limits include:

- $\tilde{g}\tilde{g}$  pair production with  $\tilde{g} \rightarrow qq\bar{q}$ , either with only light flavors or with heavy flavors among the quarks.

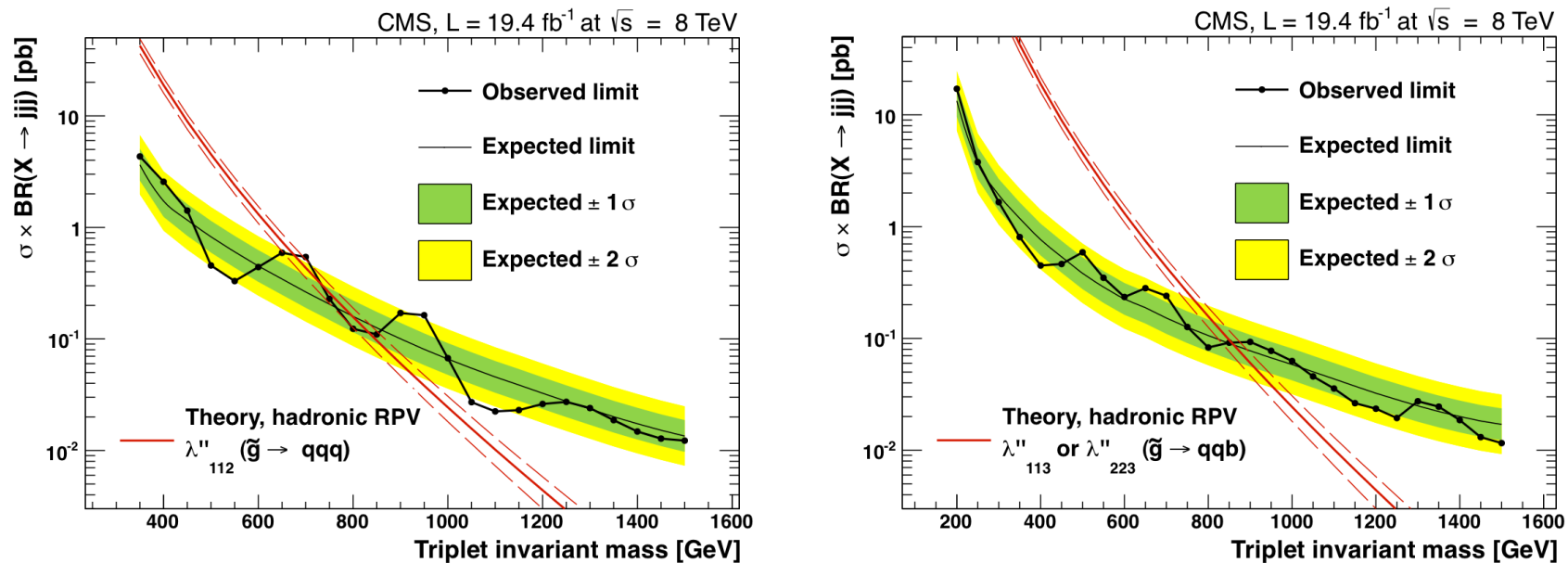

Figure 14:  $\tilde{g} \rightarrow qq\bar{q}$  limits from EXO-12-049, arXiv:1311.1799. Left: light flavors. Right: one or more  $b$  quark.

Gluino mass limits are a lot weaker than for RPC scenarios.

–  $\tilde{b}\tilde{b}$  pair production with  $\tilde{b}$  decay via BRPV

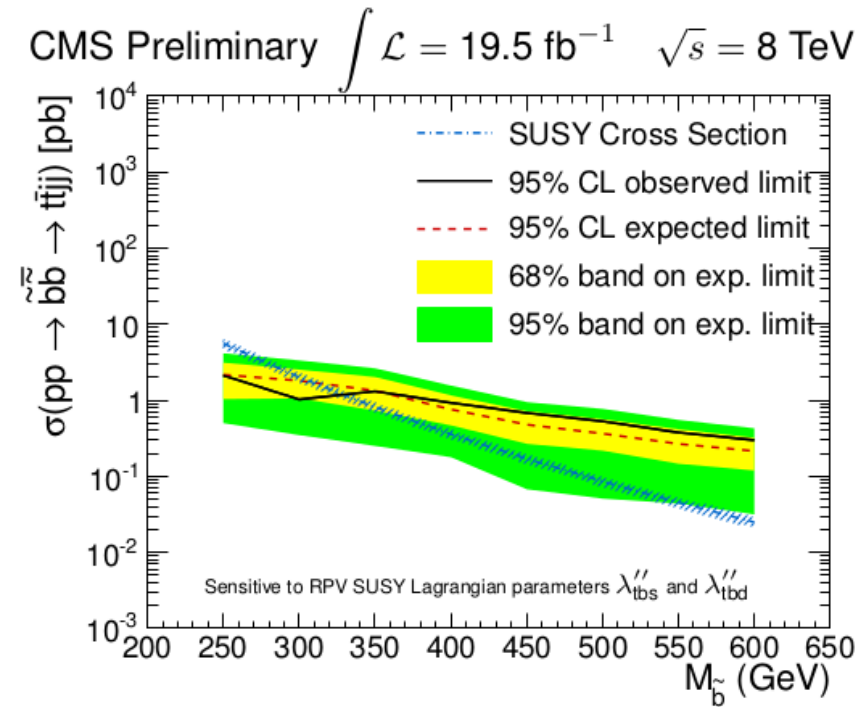
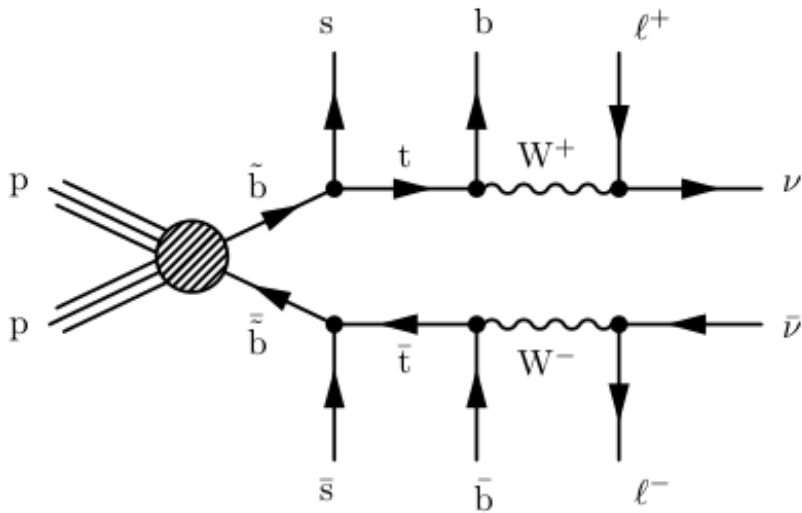

Figure 15: Limits on  $\tilde{b}\tilde{b}$  production with BRPV decays. B2G-12-008.

Sbottom mass limits are especially weak.

- $\tilde{t}\tilde{t}$  pair production with  $\tilde{t}$  decay via BRPV.

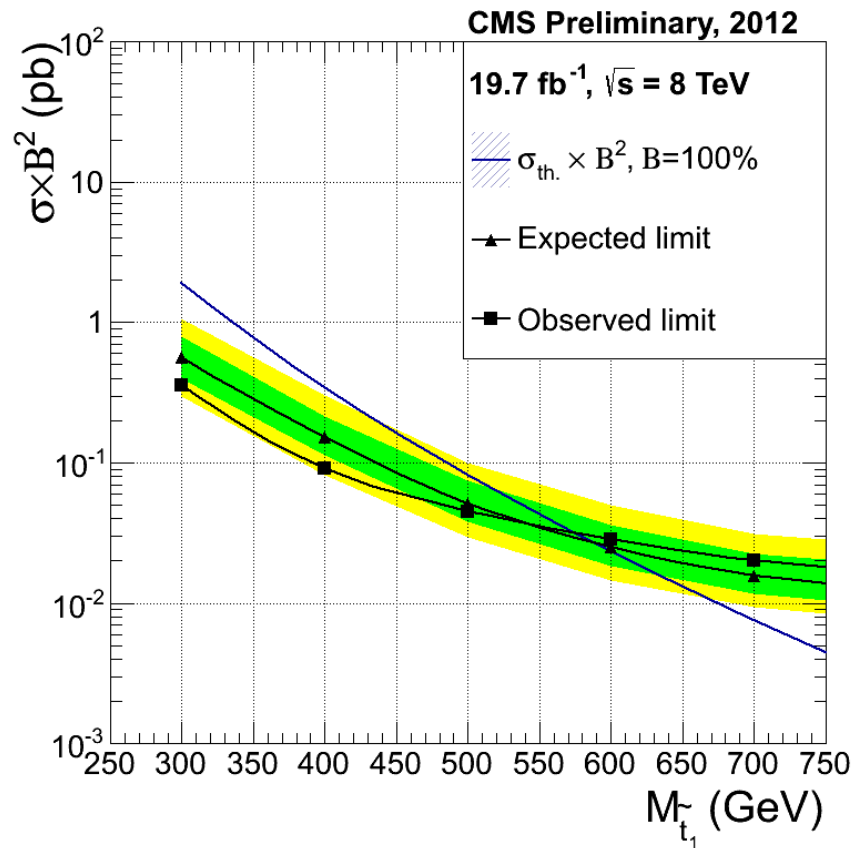

Figure 16: Limits on  $\tilde{t}\tilde{t}$  production with BRPV decays. EXO-12-032.

Stop mass limits are not particularly strong even in the experimentally most favorable BRPV decay mode.

# Alternative Dark Matter Models

- Suppose there is no SUSY or T-parity or similar symmetries that make a light Higgs boson natural.

Where can dark matter come from?

- Expanded Higgs sector

Add a singlet Higgs field that is stable because of an extra  $Z_2$  symmetry that forbids it from having couplings to  $f\bar{f}$  and from mixing with the Higgs-doublet field(s) required for standard EWSB.

An example is starting from the 2HDM and adding a singlet  $S$ . After imposing symmetries one ends up with a Higgs potential of the form:

$$V(H_1, H_2, S) = V_{2\text{HDM}} + \frac{1}{2}m_0^2 S^2 + \frac{1}{4!}\lambda_S S^4 + \kappa_1 S^2 (H_1^\dagger H_1) + \kappa_2 S^2 (H_2^\dagger H_2) \quad (1)$$

Symmetry forbids any linear terms in  $S$ . The Higgs portal couplings are the  $\kappa_1$  and  $\kappa_2$  terms that induce Higgs- $SS$  couplings when  $\langle H_1 \rangle, \langle H_2 \rangle \neq 0$ .

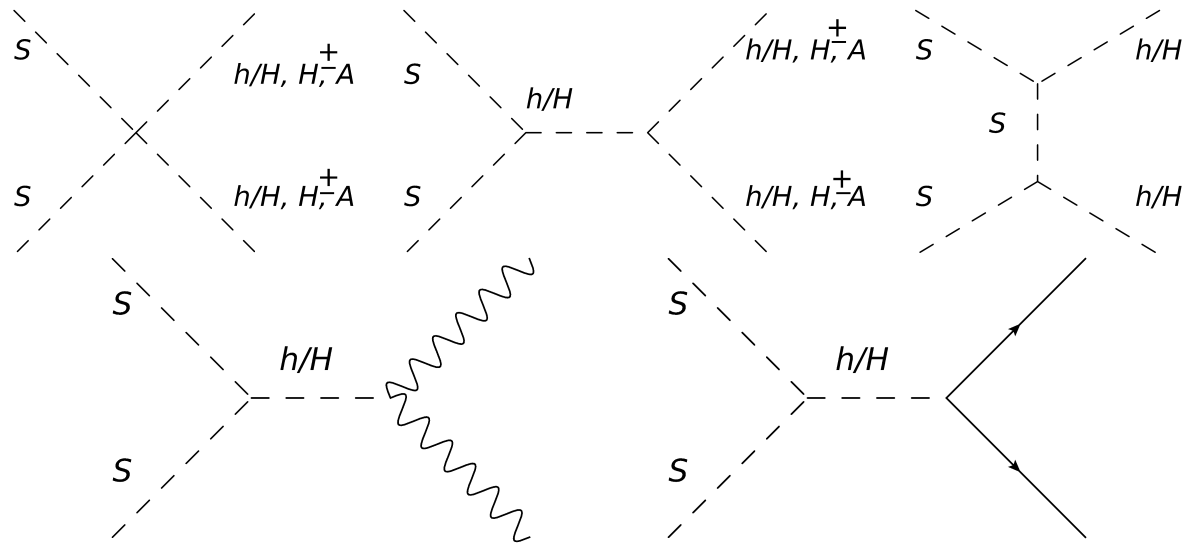

Figure 17: Singlet annihilation diagrams relevant for the relic density calculation.

Singlets are made and annihilate in the early universe by Higgs-related diagrams.

Identifying  $h$  of 2HDM sector with the 126 GeV state, one can retain good Higgs fits and get perfectly reasonable dark matter scenarios obeying all limits.

Possibilities in the  $m_S < 125 \text{ GeV}/2$  region are limited by the need to have very small  $hSS$  coupling to keep  $\mathcal{B}(h \rightarrow SS) < 0.1$  so as to preserve the Higgs fits.

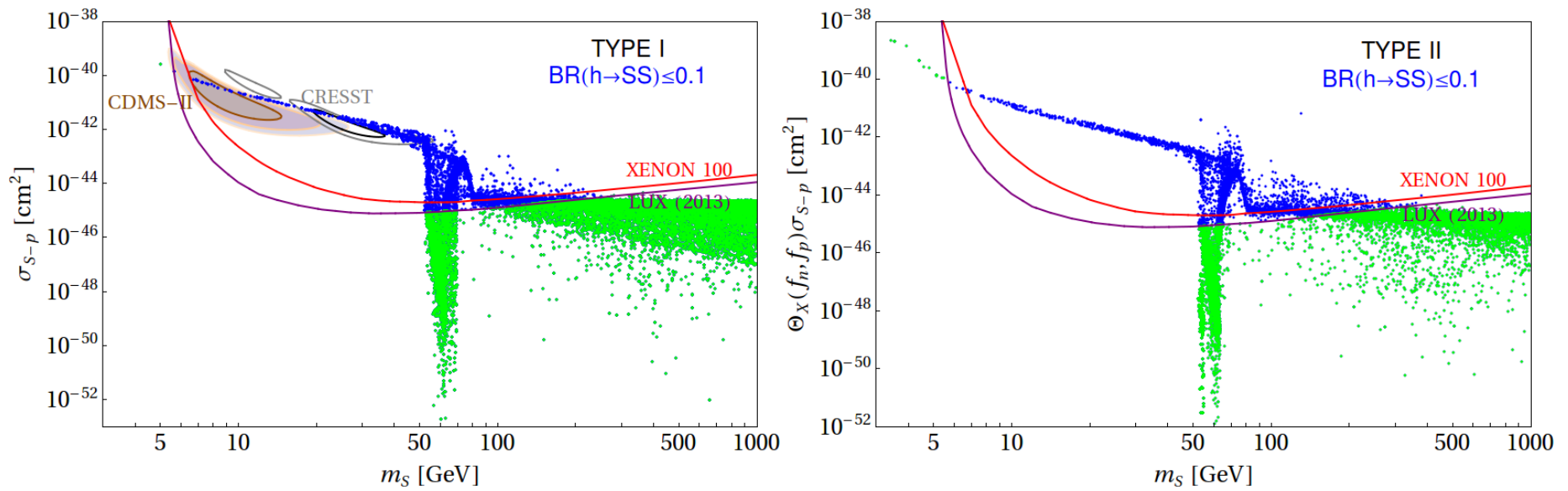

Figure 18: Cross section for DM - proton scattering for the type I and type II] models. All points shown satisfy the full set of preLUX constraints, including  $\mathcal{B}(h \rightarrow SS) < 0.1$ , while the green points satisfy in addition the LUX limits.

- Axion dark matter

”There are viable theories and there are natural and elegant theories. However, all viable, natural and elegant theories contain dark-matter axions” - Ann Nelson.

Physics has two perplexing mysteries:

- What suppresses the expected large amount of CP violation in the strong

interactions (the "Strong CP Problem");  
– and the nature of dark matter.

The axion is a hypothetical elementary particle originally postulated to solve the strong CP problem. The axion is also an extremely attractive dark matter candidate.

The axion would allow these two mysteries to fit naturally into our understanding of the universe.

In the early universe, cold axion populations arise from vacuum realignment and string and wall decay. Which mechanisms contribute depends on whether the Peccei-Quinn symmetry breaks before or after inflation.

These cold axions were never in thermal equilibrium with the rest of the universe and could provide the missing dark matter.

Unfortunately, the axions have very small mass (given many years of experimental limits) and are very weakly interacting, and of course very long lived.

Their interactions with normal matter are so weak that they cannot be produced at a reasonable rate at a collider. (If they could be produced, then they would constitute invisible energy/momentum and so tagging via ISR photon and jet would be needed.)



Basically, this is a bad news scenario for CMS — one needs an experiment like ADMX.

SUSY is still needed to solve naturalness, but it could be RPV SUSY for which the neutralino or other LSP would not be stable.  $\Rightarrow$  pay more attention to RPV scenarios.

## Conclusions

- It seems quite certain that the Higgs responsible for EWSB has emerged.
- At the moment, there is no sign of other Higgs-like signals except  $\sim 1\sigma$  hints at  $\sim 135$  GeV and the old LEP excess at 98 GeV.
- Survival of enhanced signals for the 125 GeV state (as still seen by ATLAS) would be one of the most exciting outcomes of the next LHC run and would guarantee years of theoretical and experimental exploration of BSM models with elementary scalars.
- Close to SM signals at the LHC would imply that a linear collider or LEP3 or muon collider might be needed to look for BSM physics indirectly via deviations of Higgs properties from the SM.
- Although current data is converging to a SM-like Higgs, there is still room for additional Higgs bosons in important model classes.

Thus, we must push hard to improve limits/sensitivity to additional Higgs bosons.

- SUSY remains the best-motivated technically natural model. But, it is being pushed.

If there is some kind of high-scale unification, then low FT is best accommodated in the NMSSM.

The pMSSM sets SUSY scales without regard to the ultimate high-scale theory — this may be quite appropriate in the context of the string landscape.

- Perhaps it is best to separate Dark Matter from SUSY!
  - Correct  $\Omega h^2$  is quite improbable, even in the pMSSM approach.
  - RP conservation implies SUSY is kind of easy to see if at low mass and so now limits are uncomfortably (*i.e.* unnaturally) high.
  - The axion is in any case needed for the strong CP problem and is certainly an excellent dark matter candidate.

The two big questions/bottom lines are:

- **Whither Higgs?** — fortunately, **we need not worry about Wither Higgs?**.
- However, despite G. Ross's objection to the **Wither SUSY?** option, it is becoming increasingly frustrating to continue the **Whither SUSY?** approach.

In any case, while the waiting for a 1st Higgs signal is over, watching for more Higgs or some sign of BSM is not:

